

ENGINEERED FOR FIRE SAFETY AND YOUR PEACE OF MIND

Diffuser optimised LED



8W LED
similar to 75W
Incandescent



Model:
LDL100

Energy Efficient
Downlight



Basic installation instructions:

Install using a registered electrician. Isolate the electrical power supply.

1. Minimum cavity depth required 180mmH.
2. When choosing downlight position ensure that MIC=25mm, SCB=20mm, HCB=20mm.
3. Cavity size must not be less than 0.1m².
4. Cut a 100mm diameter hole in the ceiling.
5. Connect power supply to connector block, Brown-(L) and Blue-(N).
6. Close the terminal block cover and clamp the supply cable.
7. Insert the LDL100 into the ceiling by holding back the 2 spring clips and slide into the ceiling.
8. Dimmable with clipsal and PDL dimmer switches universal and trailing edge.

Installation:

Class IC = Insulation contact.

This luminaire can only be abutted and covered with building insulation of Glass wool type. Loose fill insulation as defined in NZS4246 is not permitted to abut or cover the luminaire.

Please note that this downlight must not be installed where ambient temperatures exceed 35degrees.

Caution: Recessed Luminaires and their associated equipment may pose risk of fire damage to property if not installed and maintained correctly. Refer to AS/NZS 3000 before installation of Recessed luminaires and associated equipment.

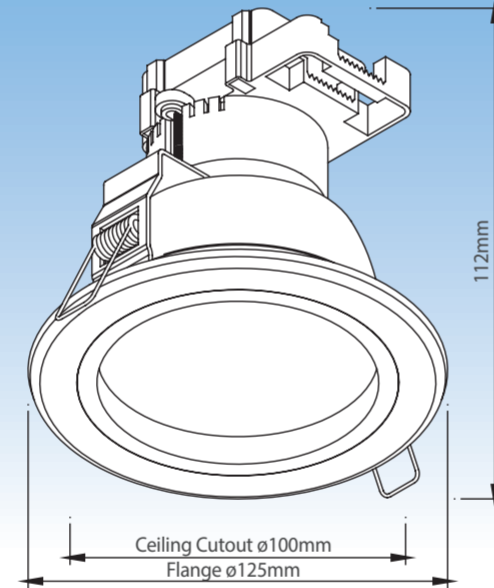

- 8 Watt LED
- Lumens = 500
- Colour temp 3,000k
- IC - Insulation Contact
- Dimmable

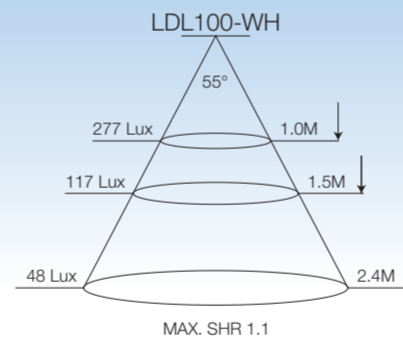

Model:
LDL100
Energy Efficient
Downlight



8W LED
similar to 75W
Incandescent



Features

- Enclosed body retains buildings thermal envelope
- Forward traveling heat sinking to dissipate heat below the ceiling to ensure optimum light output and life of LED light source.
- Integral driver for easy installation, no need to mix and match components at your own peril.
- Large easy looping terminal block for quick and easy installation.
- 8W LED similar to 75W Incandescent
- Diffuser Optimised LED
- Engineered for fire safety for your peace of mind
- Dimmable

LDL100-WH



Colour: **WHITE**

Manufactured in China



Easy looping terminal block

Diffuser optimised LED

ENGINEERED FOR FIRE SAFETY AND YOUR PEACE OF MIND

Copyright Design © 2012

Z029

ENGINEERED FOR FIRE SAFETY AND YOUR PEACE OF MIND

Copyright Design © 2012

Gartner Superlux Ltd

AUCKLAND NEW ZEALAND.

Superlux Pty Ltd

SYDNEY AUSTRALIA.